

# AlGaAs Infrared Laser Diode

**ADL-85051SL**

6-2D-LD85-012 Rev.00

## 850nm 5mW 3.3 φ TO-Type Laser Diode

### • Features

1. Low operation current
2. Cost effective

### • Applications

1. Bar-code scanner
2. Laser printer
3. Military

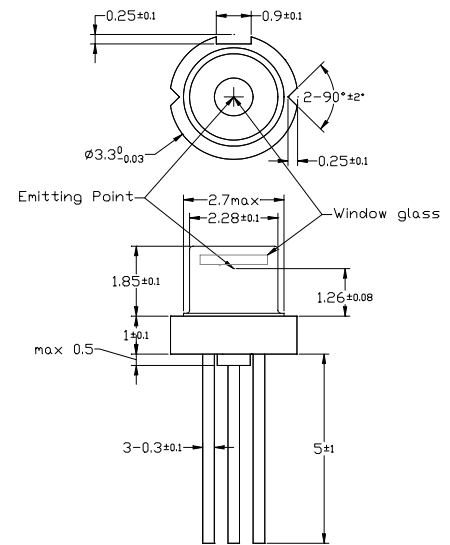

### • Absolute maximum ratings

Parameter	Symbol	Condition	Rating	Unit
Light output power	P <sub>O</sub>	CW	7	mW
Reverse voltage (LD)	V <sub>RL</sub>	-	2	V
Reverse voltage (PD)	V <sub>RD</sub>	-	30	V
Forward current (PD)	I <sub>FD</sub>	-	10	mA
Case temperature	T <sub>C</sub>	-	-10~+50	°C
Storage temperature	T <sub>S</sub>	-	-40~+85	°C

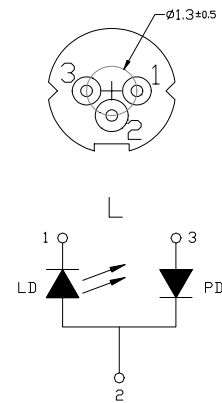

### • Electrical and optical characteristics (T<sub>c</sub>=25 °C)

Parameter	Symbol	Min.	Typ.	Max.	Unit	Conditions
Peak wavelength	λ	840	845	850	nm	P <sub>o</sub> =5mW
Threshold current	I <sub>th</sub>	-	19	25	mA	
Operating current	I <sub>op</sub>	-	26	35	mA	P <sub>o</sub> =5mW
Operating voltage	V <sub>op</sub>	-	1.8	2.0	V	P <sub>o</sub> =5mW
Differential efficiency	η	0.5	0.9	1.1	mW/mA	P <sub>o</sub> =3-5mW
Monitor current	I <sub>m</sub>	0.2	0.5	0.8	mA	P <sub>o</sub> =5mW, V <sub>RD</sub> =5V
Parallel divergence angle	θ <sub>  </sub>	6	9	12	degree	P <sub>o</sub> =5mW
Perpendicular divergence angle	θ <sub>⊥</sub>	27	32	36	degree	
Parallel FFP deviation angle	Δθ <sub>  </sub>	-3	-	+3	deg	
Perpendicular FFP deviation angle	Δθ <sub>⊥</sub>	-3	-	+3	deg	
Emission point accuracy	ΔxΔyΔz'	-80	-	+80	um	

### • Precautions

- \* Do not operate the device above maximum ratings. Doing so may cause unexpected and permanent damage to the device.
- \* Take precautions to avoid electrostatic discharge and/or momentary power spikes. A change in the characteristics of the laser or premature failure may result.
- \* Proper heat sinking of the device assures stability and lifetime. Always ensure that maximum operating temperatures are not exceeded.
- \* Observing visible or invisible laser beams with the human eye directly, or indirectly, can cause permanent damage. Use a camera to observe the laser.
- \* No laser device should be used in any application or situation where life or property is at risk in event of device failure.
- \* Specifications are subject to change without notice. Ensure that you have the latest specification by contacting us prior to purchase or use of the product.

\* For reference only. Contents above are subject to change without notice.

**Arima**  
LASERS

